

Exploded View for Goulds 3196, Summit 2196, Peerless 8196, Griswold 811 and other ANSI equivalents

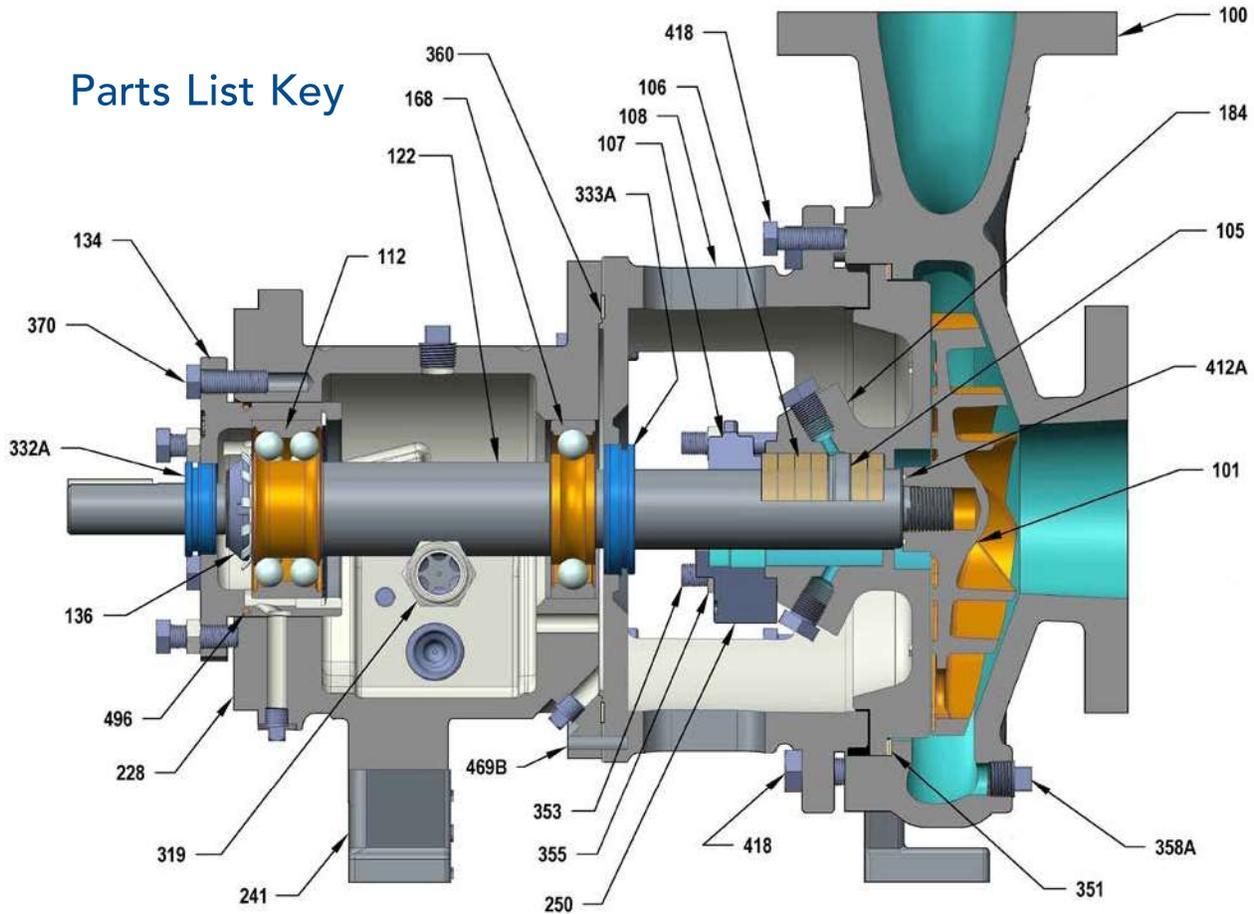

Parts and Material Composition

| ITEM NO. | REQ'D PER PUMP | PART NAME | ALL DUCTILE IRON | ALL 316SS | ALL ALLOY 20 | ALL CD4MCuN |
|----------|----------------|--|-------------------------------------|-----------|--------------|-------------|
| 100 | 1 | Casing | DI | 316SS | Alloy 20 | CD4MCuN |
| 101 | 1 | Impeller | DI | 316SS | Alloy 20 | CD4MCuN |
| 105 | 1 | Lantern Ring | Glass-Filled TFE | | | |
| 106 | 1 | Packing | SIL C-8201 Acid Rest. | | TFE | |
| 107 | 1 | Packing Gland | 316SS | | Alloy 20 | |
| 108 | 1 | Frame Adapter | Ductile Iron | | | |
| 112 | 1 | Outboard (Thrust) Bearing | Double-Row Angular Contact** | | | |
| 122 | 1 | Shaft - Less Sleeve (Optional - Shown) | 316SS | | Alloy 20 | |
| 122 | 1 | Shaft - With Sleeve (Not Shown) | SAE4140 | | | |
| 126 | 1 | Shaft Sleeve (Not Shown) | 316SS | | Alloy 20 | |
| 134 | 1 | Bearing Housing | Cast Iron | | | |
| 136 | 1 | Lock Nut / Lock Washer | Steel | | | |
| 168 | 1 | Inboard (Radial) Bearing | Single-Row Deep Groove | | | |
| 184 | 1 | Stuffing Box | DI | 316SS | Alloy 20 | CD4MCuN |
| 228 | 1 | Frame | Cast Iron (Ductile for Small Frame) | | | |
| 241 | 1 | Frame Foot | Cast Iron | | | |

| ITEM NO. | REQ'D PER PUMP | PART NAME | ALL DUCTILE IRON | ALL 316SS | ALL ALLOY 20 | ALL CD4MCuN |
|----------|----------------|-------------------------------|--------------------------------------|-----------|--------------|-------------|
| 250 | 1 | Mechanical Seal Gland | 316SS | | Alloy 20 | |
| 319 | 1 | Sight-Oil Gauge | Cad. Plated | | | |
| 332A | 1 | Labyrinth Oil Seal (Outboard) | Bronze (Optional Carbon Filled PTFE) | | | |
| 333A | 1 | Labyrinth Oil Seal (Inboard) | Bronze (Optional Carbon-Filled PTFE) | | | |
| 351 | 1 | Casing Gasket | Aramid Fiber with EPDM Rubber | | | |
| 353 | 4 | Gland Stud | 316SS | | | |
| 355 | 4 | Gland Nut | 304SS | | | |
| 358A | 1 | Casing Drain Plug | Steel | 316SS | Alloy 20*** | 316SS*** |
| 360 | 1 | Gasket, Frame-to-Adapter | Vellumoid | | | |
| 360A | 1 | Gasket, Bearing-End Cover | Vellumoid (XL Only) | | | |
| 370 | 3 | Bearing Housing Hex Bolt | Steel | | | |
| 412A | 1 | Impeller O-Ring | Glass-Filled TFE | | | |
| 418 | 3 | Casing Jack Screw | Steel | | | |
| 469B | 2 | Dowel Pin | Steel | | | |
| 496 | 1 | Bearing Housing O-Ring | Buna Rubber | | | |